



EI1-30 | SINGLE & DOUBLE TWO-WAY DOOR

FTHE 0301 | Fire resistance EI1-30 (in accordance with EN 1634-1)

Fire resistance

Tests carried out by the University of Liège.
Classification Report C0069



All Heinen doors are constructed on the basis of the METAL+ concept, lending them superior basic performance standards.

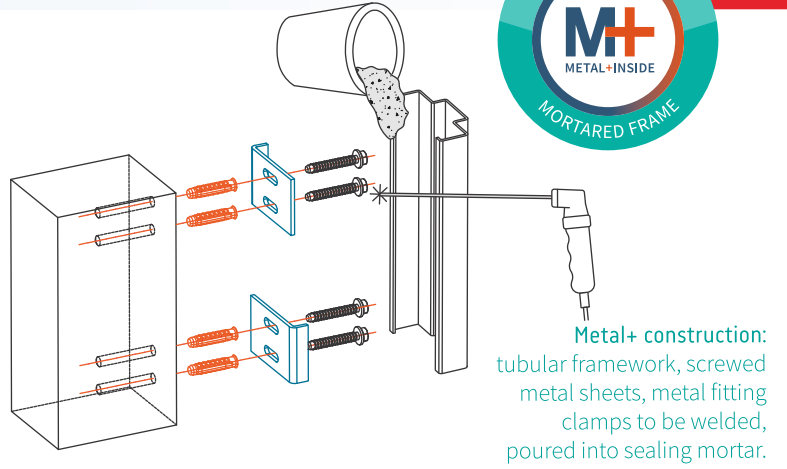

Basic performance features of the EI1-30 two-way door



Fire resistance (EN 1634-1)
EI1-30



Radiation
EW 60



Frequency of use
Up to 500,000 open/close cycles
(Based on tests of the GEZE TS 550NV FP soil pivot)



Mechanical resistance
Enhanced mechanical resistance



Service life of the door
15-year warranty on the door set

CROSS-SECTION EI1-30 TWO-WAY DOOR (DRHE 0301)

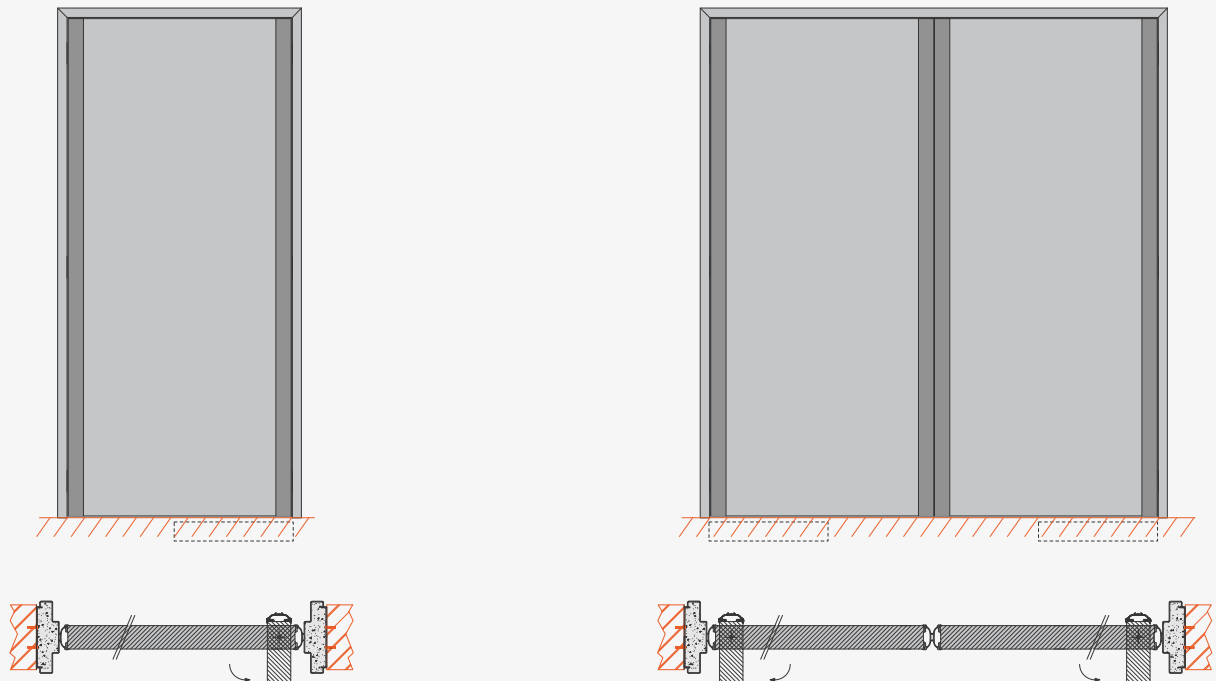

DOOR DIMENSIONS *(always customised)*

Single door

	Min. dimensions		Max. dimensions		Max. surf.
	W	H	W	H	
Leaf	600	1702	1380	2610	3.26m ²
Opening	790	1800	1570	2708	

Calculation of clear passage:

FP 90° = Width of opening - 255

FP = Height of opening - 90

The surface area stated for double doors is the sum of the surface areas of the 2 door leaves. Construction support with a minimum thickness of 190 mm and a minimum density of 480 kg/m. On request, larger/smaller door units are also available outside the certificate, as are wall thicknesses.

The dimensions of the leaves indicated in the Efectis classification certificates may vary from the University of Liège classification reports. For more details, see DOHE 012: Minimum and maximum dimensions of fire doors to EN 1634-1.

Double door

	Min. dimensions		Max. dimensions		Max. surf.
	W	H	W	H	
Leaf	600	1702	1380	2610	6.52m ²
Opening	1440	1800	3000	2708	

Calculation of clear passage:

FP 90° = Width of opening - 370

FP = Height of opening - 90

SECURITY LOCKS

Mechanical systems

Top and/or bottom lock *

*Compatibel with Electronic lock Fail safe.

Manual locking

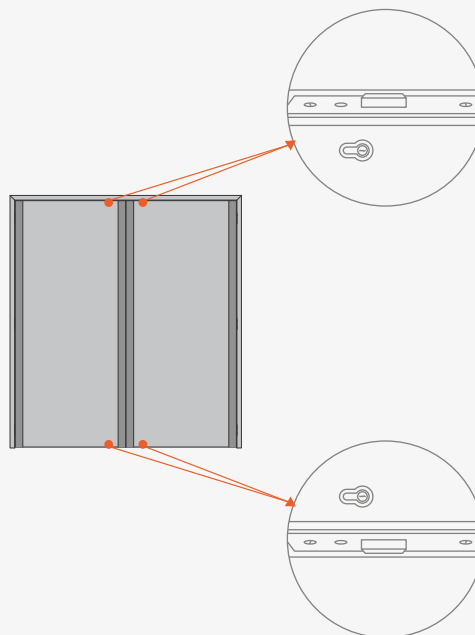

WINDOW CONFIGURATIONS

Solid or glazed. Standard sizes or customised windows (SM).

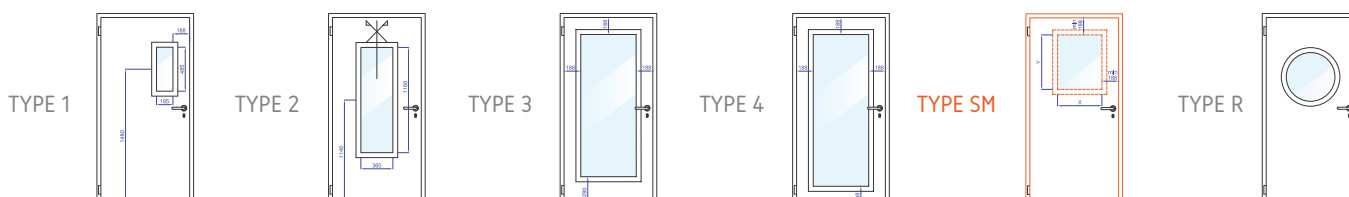

FITTINGS

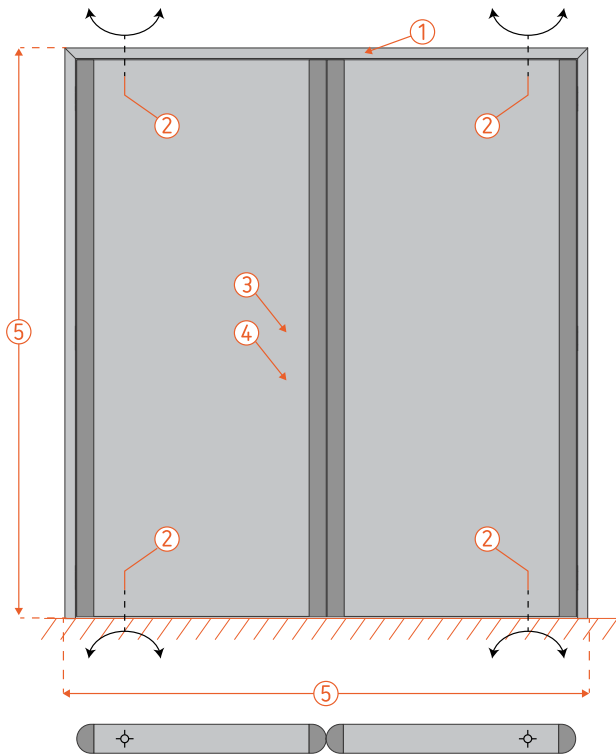

BASIC FITTINGS

- 1 | **Door frame and leaf finish**
Magnelis® Hot-dip galvanised ZM 250 steel (250g/m, 20m thick).
- 2 | **Pivot hinges**
Two stainless steel pivot hinges (one pivot hinge in the floor and one in the frame).
The pivot hinges serve as door closers.
- 3 | **Handles**
No handles.
- 4 | **Lock and cylinder**
No lock.
- 5 | **Double door**
One double swing door has two operating leaves; there is no priority leaf.
Note: for reasons of safety, we recommend a little peep-hole (glazing).

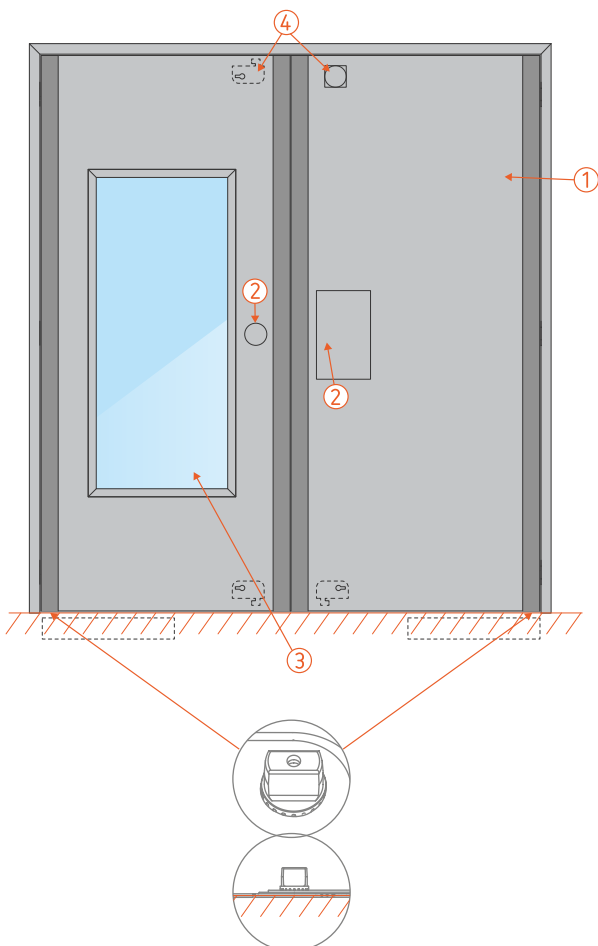

OPTIONAL FITTINGS

- 1 | **Door frame and leaf finish**
Stainless steel 304, 316 or RAL paint.
- 2 | **Handles**
Doorknobs, pull handles etc. in aluminium or stainless steel.
Push plate in stainless steel.
- 3 | **Glazing**
Peep-hole glazing (standard size/custom-made), extensively glazed doors, many types of glazing.
- 4 | **Locks and closing systems**
Magnetic retainer / No lock (closes thanks to pivot hinges only) / High and/or low locks (closes with deadbolt only).
- 5 | **Remote surveillance**
Indication of leaf position.
- 6 | **Various options**
Door stops, impact plates.

Heinen doors can combine performance features on a bespoke basis. Depending on your needs, one or more performance features are added to the basic, robust Metal+ door. Some performances are only available with the welded and mortar filled installation method.



Fire resistance



Burglary resistance



Acoustic performance



Bullet-proof



Blast-proof



Electromagnetic



Anti-panic



Smoke tightness



Thermal insulation



Airtightness



Watertightness



Wind resistance



www.heinen-doors.com

For BIM files, please consult us.

Heinen product sheet | E11-30 | SINGLE & DOUBLE TWO-WAY DOOR | 2024-08-11_FTHe 0301 - V08EN

Copyright © Heinen 2024 | Non-contractual document.